



best in the
LongRun

Adjustable Angle Side Roller Guide On's

Assembly/Installation Instructions

Part #86106

Thank you for purchasing the TIE DOWN ENGINEERING Roller Guides. Please review the following instructions before starting the assembly. With proper care, the Roller Guides will give you years of service.

Tools Required

9/16" Deep Socket and 9/16" Wrench

This kit contains the following components:

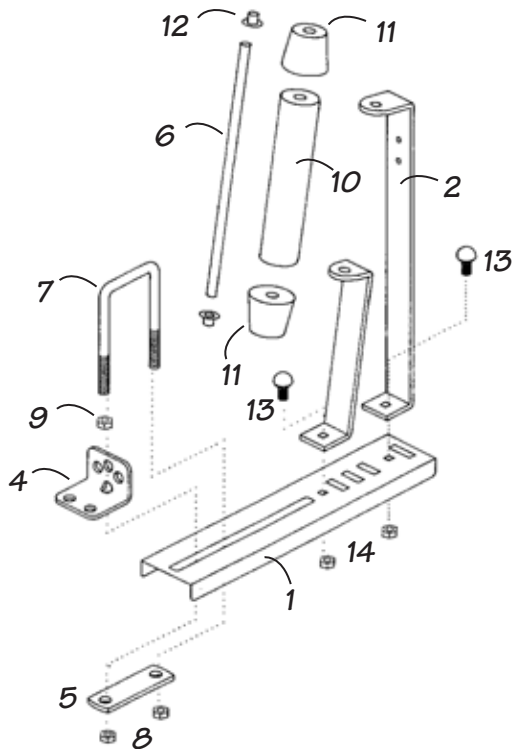

#	Qty.	Part #	Description
1	2	48071	Roller Guide Base.
2	2	48072	Long Roller Guide Bracket
3	2	48073	Short Roller Guide Bracket
4	2	48076	Angle Adjuster
5	2	48010	Link Bar
6	2	44615	Roller Shaft
7	2	10986Z	U Bolt
8	4	10645	Nyloc Nut 1/2"
9	2	10646Y	1/2" 13NC Hex. Nut
10	2	17049	Roller
11	4	17085	2" End Cap
12	6	10088	Cap Nut
13	4	10804	Carriage Bolt 3/8" x 1"
14	4	10627	Nyloc Nut 3/8"

Installing your Boat Guides:

1. Determine the position for the guides on your trailer frame. (roller guides are normally installed halfway between wheels and back of trailer.)
2. Place U-bolt over frame. Determine the hole in angle adjuster that most closely fits your frame width and slide angle adjuster over inside leg of U -bolt.

Note - For frames less than 3" wide and more than 3" deep, thread 1/2" nut onto U-bolt first.





Adjustable Angle Side Roller Guide On's

Assembly/Installation Instructions
Part #86106

3. Hold guide base under frame with U-bolt ends through slot in base. Place link bar over U-bolt, attach with nyloc nuts, hand tighten at this time.
4. Insert long roller guide bracket into outside slot of roller guide base as shown in Figure 1. Insert carriage bolt and turn Nut on loosely.
5. Attach cap nut to one end of roller shaft only. Insert short roller guide bracket into any slot in roller guide base and insert roller. Now insert roller shaft from top. Repeat these steps, using the remaining two slots to determine the best Roller angle for your boat's hull.
6. Once you have determined the correct roller angle and slot, insert the remaining carriage bolt and loosely attach the nyloc nut.
7. Now insert roller between long and short roller guide brackets and insert roller shaft through top end cap, roller and bottom end cap. Attach remaining cap nut. Hold a hammer under roller shaft and tap top of shaft to firmly attach cap nuts. (Your kit includes two extra cap nuts should you have to remove one.)
8. Adjust guide base for boat width and torque all nuts 20 to 25 ft./lbs.
Note - It is important to tighten U -bolt nuts evenly.

